

1	2	3	4	5
Pos.Nr.	Artikelnummer	Menge	ERP Artikel	Beschreibung2
1	21-11-45844	1	03-99-0487	BG-CL3G V2021-Grundbaugruppe
2	21-11-45970	1	03-99-0510	BG-CL3G V2021-4-W/K-45Liter
3	21-10-45351	1	03-99-0491	BG-CL3G V2021-FS
4	21-11-45831	1	03-99-0486	BG-CL3G V2021-Manometer xDR-40 Rückwand
5	21-11-45971	1	03-99-0511	BG-CL3G V2021 Innenleben Kaskadenfilter
6	22-02-46827	1	01-03-1291	RGBW LED Leuchte CL3GV2021; 70016294 / LSX0840-0015
7	15-03-13027	1	03-10-0085	CL916_25bar_EMA3
8	21-12-46281	1	03-99-0530	BGR CL3G V2021 Motor-Pumpen-Einheit 55-40-K
9	21-11-45968	1	03-99-0508	BG-CL3G V2021-TP-KSP III
10	21-10-45361	1	03-99-0492	BG-CL3G V2021-VST-150bar
11	19-05-31541	1	01-01-2604	MR1K-015GM004-36; Durchflusswächter
12	14-10-11791	1	01-04-2181	GE15LR;DSA15RL
13	19-06-32264	1	01-04-5123	EVW15L45°;BFDKO15L/45°
14	14-08-11389	1	01-04-1757	EVGE15LR;DSVA15RL
15	19-07-32385	1	01-01-2015	KE3093DRG500ZYLFKM_197
16	19-07-32384	1	01-01-2120	KE3094 KS DRG 040 FKM/K197
17	22-07-48976	1	01-04-5429	2SCS 12 A25A35-840 V=70°

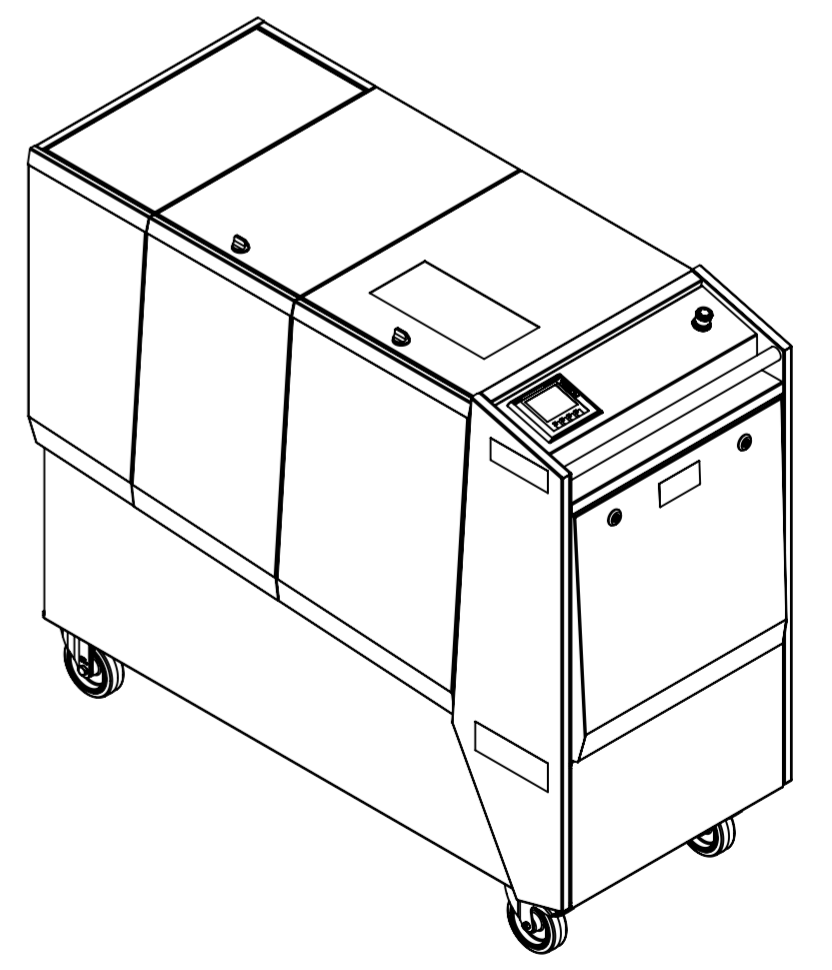
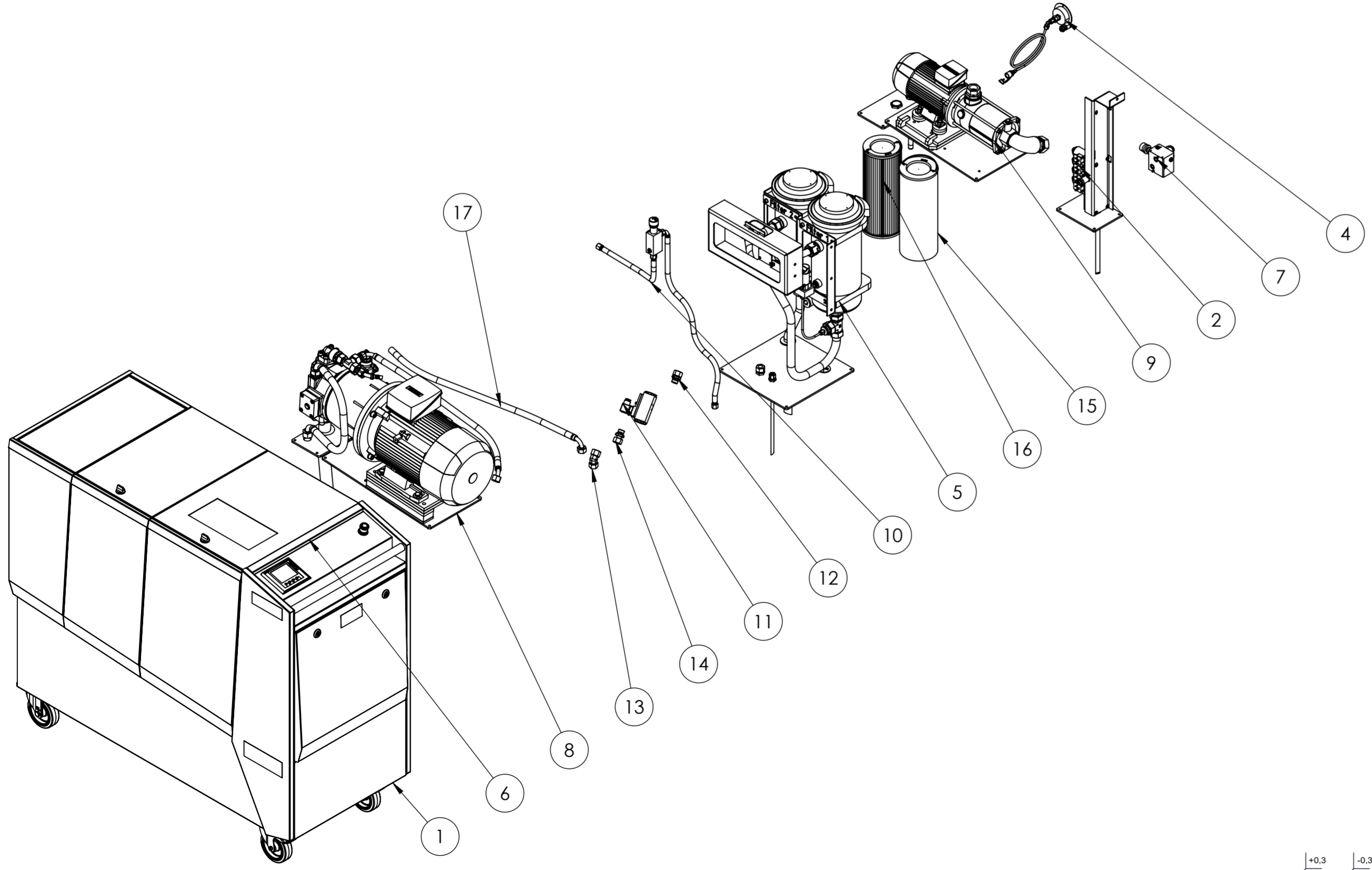
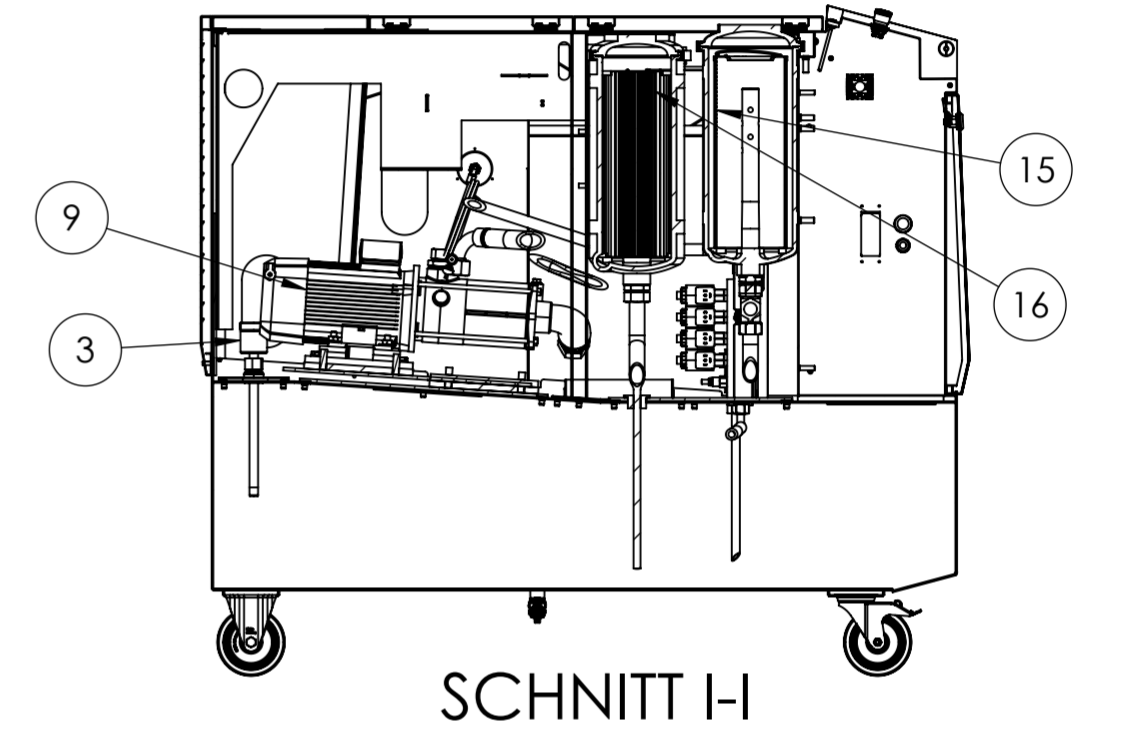
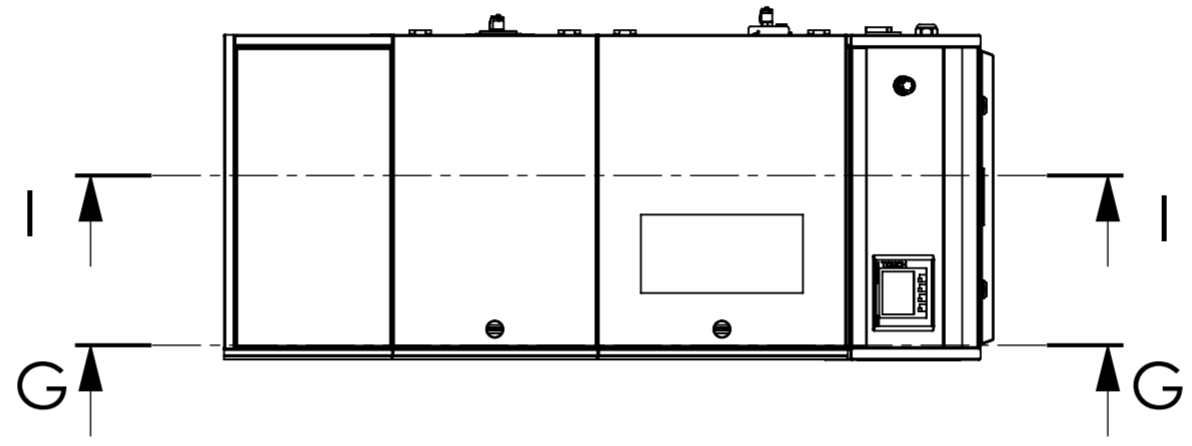
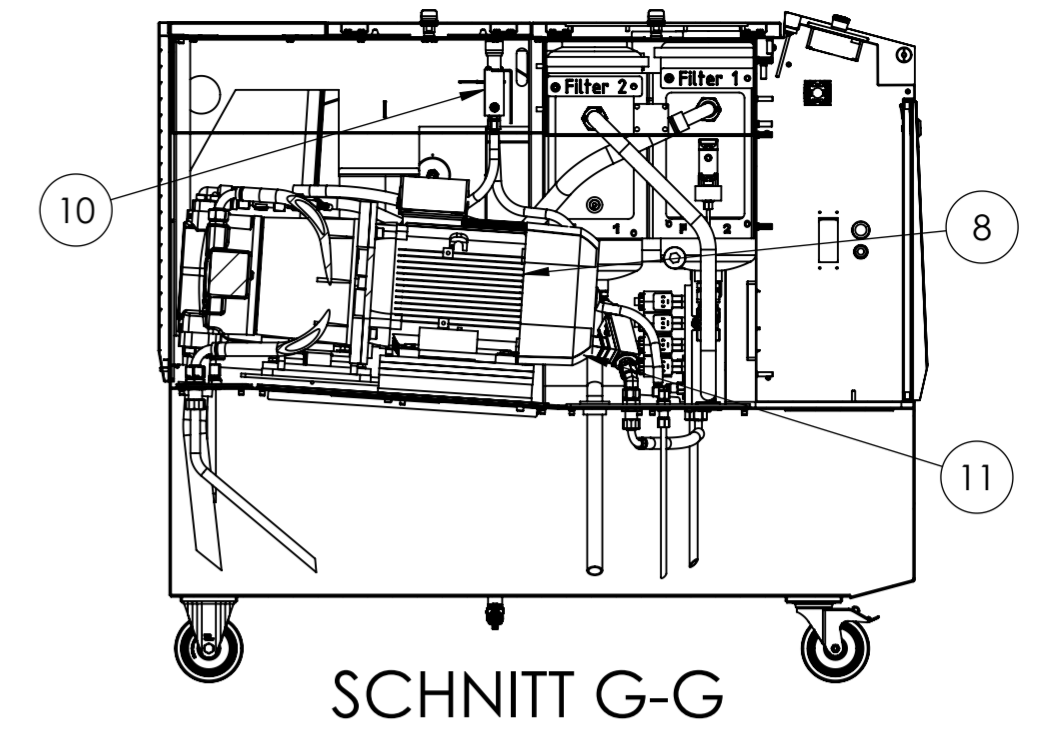
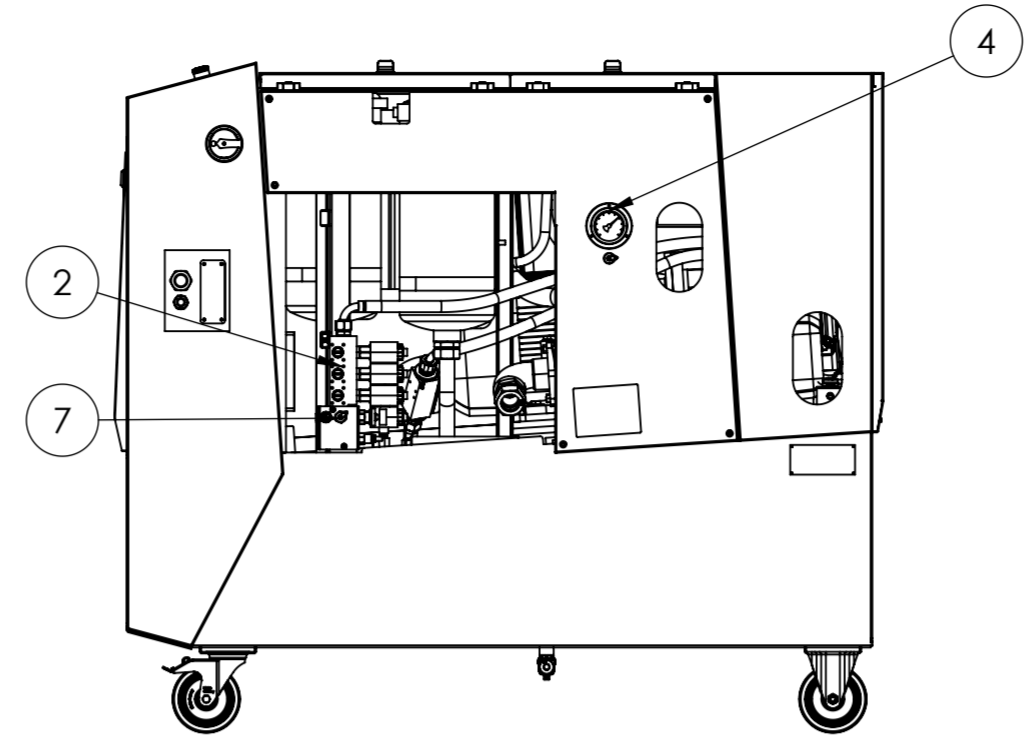

Diese Zeichnung ist urheberrechtlich geschützt und darf ohne die schriftliche Zustimmung der Firma Müller Hydraulik GmbH keinen Dritten inhaltlich mitgeteilt noch ausgehändigt werden!

Allgemein-toleranzen  
DIN ISO 2768-mK  
Datum  
Erstellt 25.07.2022  
Freig.  
Name  
xsun

Rohabmessung:  
Material:  
Gewicht: 0.00 kg  
ERP-Artikel:  
Benennung:  
**CL3G-F-55-40-E-040-XX-4-K-1DR-NOT**  
Zeichnungsnummer:  
**22-07-48973**  
Status  
freigegeben  
Revision  
02  
Format  
A2  
Blatt / von  
2 / 2  
Maßstab: 1:14

W = ✓  
V = ✓ Rz100  
Y = ✓ Rz25  
Z = ✓ Rz6.3

